

S.A.M. 308f FB

AUFSCHNITTVOLLAUTOMAT FULLY AUTOMATIC SLICER



schneiden
slicing



ablegen
depositing



Elektronisch gesteuerte System-Aufschnittmaschine. Vollautomat mit elektronisch gesteuertem Schnittgutwagen.

Electronically controlled fully automatic slicer with electronically controlled carriage.

- > 4 Ablegevarianten: Quer-, Längs-, Stapel- und Rundablage, mit frei wählbarer Scheiben- und Lagenzahl.
- > Eine Ablegevariante speicherbar.
- > Automatische Produkteinspannung.
- > Motorgetriebener Schneidgutvorschub 400 mm.
- > Motorbetriebenes Förderband.
- > Vollautomatische Schnittstärkeneinstellung von 0 - 7 mm, Anschlagplatte öffnet nur während des Schneidevorgangs.

- > 4 layout options: shingles across and down, stacks, circles with any number of slices and layers.
- > One layout option can be stored.
- > Automatic product clamping.
- > Motor-powered product feed: 400 mm.
- > Motor-powered conveyor belt.
- > Fully automatic slice thickness control from 0 - 7 mm, gauge plate only opens during the slicing process.

308f FB

> Optional

- > Käsekettenrahmen, Käseausstattung, Käsemesser/Teflonmesser, Fußtaster

308f FB

> Option

- > Cheese transport-system, SamClean coating (for cheese), knife for cheese, footswitch

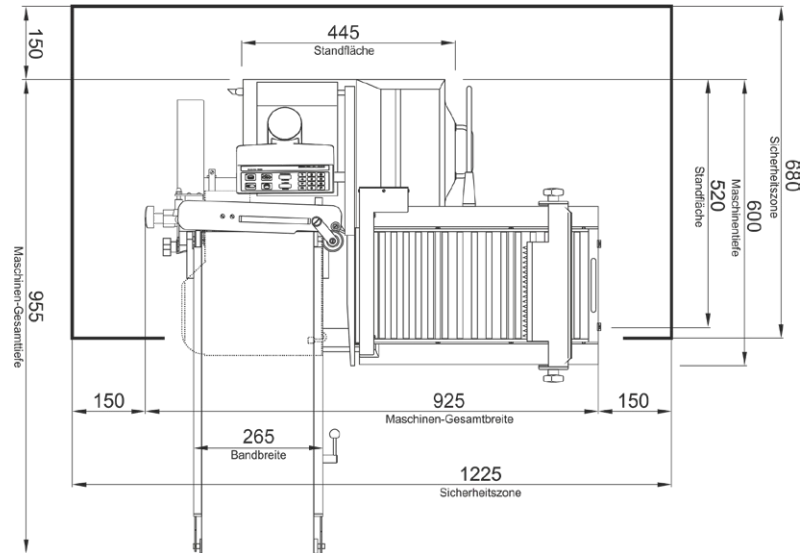

MASSE UND GEWICHT

- > Gewicht netto > 91 kg
- > Abmessungen B x T x H > 925 x 955 x 630 mm



WEIGHT AND DIMENSIONS

- > Net weight > 91 kg
- > Dimensions L x W x H > 925 x 955 x 630 mm



MECHANISCHE DATEN

- > Messergröße > 300 mm
- > Max. Schneidgutvorschub > 400 mm
- > Max. Schneidgutgröße B x H > 150 mm bzw. 210 x 140 mm
- > Scheibenstärke > 0,5 - 7 mm
- > Schnittgeschwindigkeit > 30 - 55 Schnitte / min



MECHANICAL DATA

- > Knife diameter > 300 mm
- > Max. product feed drive > 400 mm
- > Max. product size W x H > 150 mm or 210 x 140 mm
- > Slice thickness > 0,5 - 7 mm
- > Slicing speed > 30 - 55 slices / min



ELEKTRISCHE DATEN

- > Anschlußspannung/Frequenz > 230V oder 3 x 400V / 50Hz
- > Stromaufnahme 1~ / 3~ > 2,34 / 1,54 A
- > Steckdosenabsicherung > min. 10 A
- > Netzwerkschnittstellen > n/a



ELECTRICAL DATA

- > Supply voltage/frequency > 230V or 3 x 400V / 50Hz
- > Current consumption 1~ / 3~ > 2,34 / 1,54 A
- > Power outlet fuse > min. 10 A
- > Network ports > n/a



WEITERE DATEN

- > Geräuschpegel > < 70 dB(A)
- > Luftfeuchte > 30-80% nicht kondensierend
- > Temperaturbereich > +5°C bis +35°C



MORE DATA

- > Noise level > < 70 dB(A)
- > Environment humidity > 30-80% not condensing
- > Temperature range > +5°C to +35°C