

S.A.M.

# 310i Packer T



schneiden  
slicing



ablegen  
depositing



verpacken  
packing



Für die automatisierte Produktion von mehrlagigen SamPaks. Schneideparameter für bis zu 400 Produkte programmierbar. Produziert SamPaks in Verpackungsgrößen 21 x 21 oder 21 x 26 cm.

For automatic production of multi-layer SamPaks. Slicing parameters programmable for up to 400 products. Produces SamPaks in packaging sizes 21 x 21 or 21 x 26 cm.

- > 4 Ablegevarianten: Quer-, Längs-, Stapel- und Rundablage, sämtliche Schneideparameter frei wähl- und speicherbar.
- > 400 Speicherplätze mit 4-stelligen PLUs.
- > ATC (Automatic Thickness Control): Vollautomatische Präzisions-Schnittstärkeneinstellung (Genauigkeit 0,1 mm). Anschlagplatte öffnet nur während des Schneidens.

- > 4 layout options: shingles across and down, stacks, circles, all slicing parameters can be freely selected and stored.
- > Memory for 400 programs with 4-digit PLU codes.
- > ATC (Automatic Thickness Control) fully automatic precision slice thickness control - accuracy 0.1 mm - gauge plate only opens during the slicing process.

# 310i Packer T

## Optional

- > Robo Packer, Folienautomat, Käsekettenrahmen, SamClean (Käseausstattung), Käsemesser/Teflonmesser, Entenbrustschneidaufsatz, Salami-schneidaufsatz (3 Kammern), Fußtaster

# 310i Packer T

## Option

- > Robo Packer, film dispenser, cheese transport-system, SamClean-coating (for cheese), knife for cheese, goose/duck slicing attachment, salami slicing attachment (3 chambers), footswitch

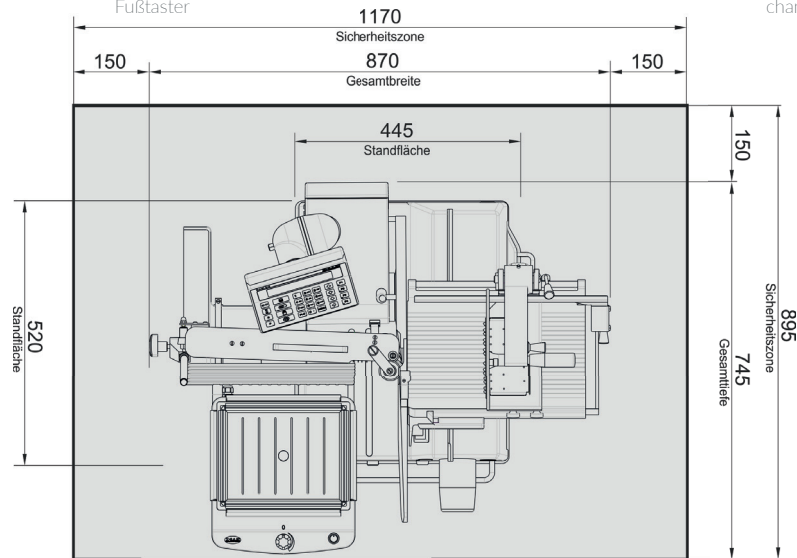

## MASSE UND GEWICHT

- > Gewicht netto > 110 kg
- > Abmessungen B x T x H > 870 x 745 x 690 mm



## WEIGHT AND DIMENSIONS

- > Net weight > 110 kg
- > Dimensions L x W x H > 870 x 745 x 690 mm



## MECHANISCHE DATEN

- > Messergröße > 300 mm
- > Max. Schneidgutvorschub > 200 mm
- > Max. Schneidgutgröße B x H > 150 mm bzw. 220 x 140 mm
- > Scheibenstärke > 0,5 - 7 mm
- > Schnittgeschwindigkeit > 30 - 55 Schnitt e/ min



## MECHANICAL DATA

- > Knife diameter > 300 mm
- > Max. product feed drive > 200 mm
- > Max. product size W x H > 150 mm or 220 x 140 mm
- > Slice thickness > 0,5 - 7 mm
- > Slicing speed > 30 - 55 slices / min



## ELEKTRISCHE DATEN

- > Anschlußspannung/Frequenz > 230V oder 3 x 400V / 50Hz
- > Stromaufnahme 1~ / 3~ > 4,1 / 3,3 A
- > Steckdosenabsicherung > min. 10 A
- > Netzwerkschnittstellen > opt. 1x Ethernet



## ELECTRICAL DATA

- > Supply voltage/frequency > 230V or 3 x 400V / 50Hz
- > Current consumption 1~ / 3~ > 4,1 / 3,3 A
- > Power outlet fuse > min. 10 A
- > Network ports > opt. 1x Ethernet



## WEITERE DATEN

- > Geräuschpegel > < 70 dB(A)
- > Umgebung > > 40 % Luftfeuchte
- > Temperaturbereich > +5°C bis +35°C
- > SamPak Format > 26 x 21 oder 21 x 21 cm
- > Verschweißbare Folien > 4
- > Max. SamPak-Höhe > 12 mm
- > SamPak-Output > Einzelfertigung



## MORE DATA

- > Noise level > < 70 dB(A)
- > Temperature range > > 40 % humidity
- > Environment > +5°C to +35°C
- > SamPak format > 26 x 21 or 21 x 21 cm
- > Sealable film layers > 4
- > Max. SamPak height > 12 mm
- > SamPak output > individual manufacture